

GCSE (9–1) Design and Technology

J310/01 Principles of Design and Technology

Sample Insert

Date – Morning/Afternoon

Time allowed: 2 hours

You must have:

- the Question Paper



INFORMATION FOR CANDIDATES

- This document is to be used when answering **Section B**.
- The images on page 8 are required to answer questions **4 and 5(c)**.
- The product information on pages 2 to 7 are required to answer questions **5 and 6**.
- The question paper tells you when to refer to the information contained in this Insert.
- This document consists of **8** pages. Any blank pages are indicated.

INSTRUCTION TO EXAMS OFFICER/INVIGILATOR

- Do not send this Insert for marking, it should be retained in the centre or recycled. Please contact OCR Copyright should you wish to re-use this document.

Product 1 - Coffee cup (papers and boards)

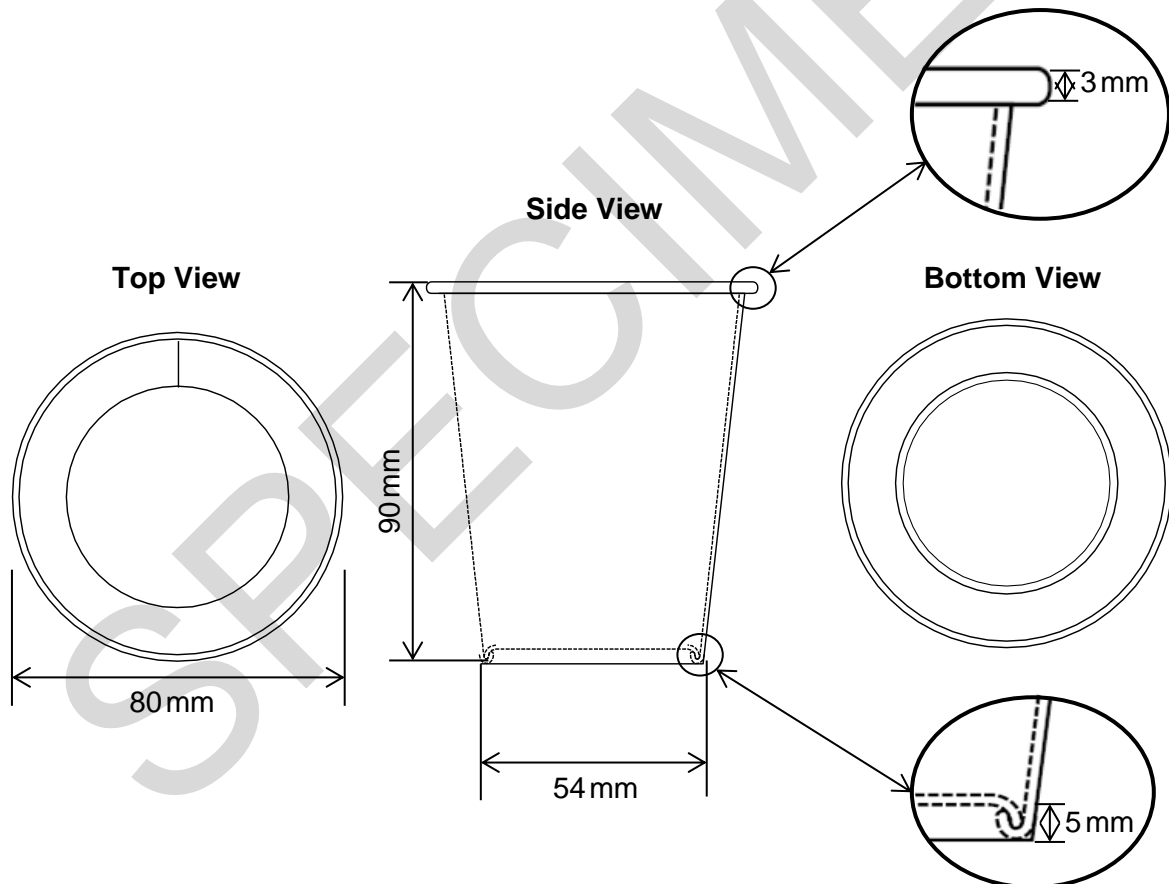

The coffee cup would be made in bulk quantities. To make a final prototype the following needs to be considered in your step-by-step plan:

- how the printing and the design are laid out, so that stakeholders can see a flat sheet that hasn't been made up into a cup
- how to produce a made up coffee cup
- the coffee cup that has been designed is recyclable.

Product 2 – High visibility jacket (fibres and fabrics)

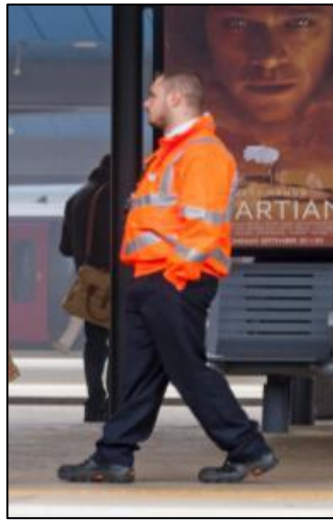

Front View

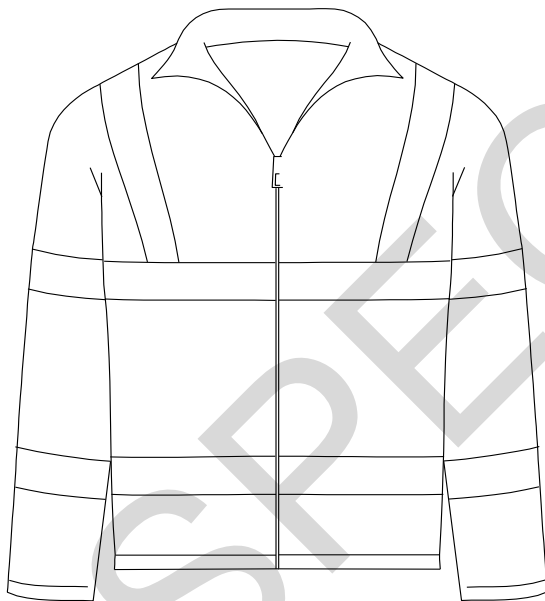

Back View

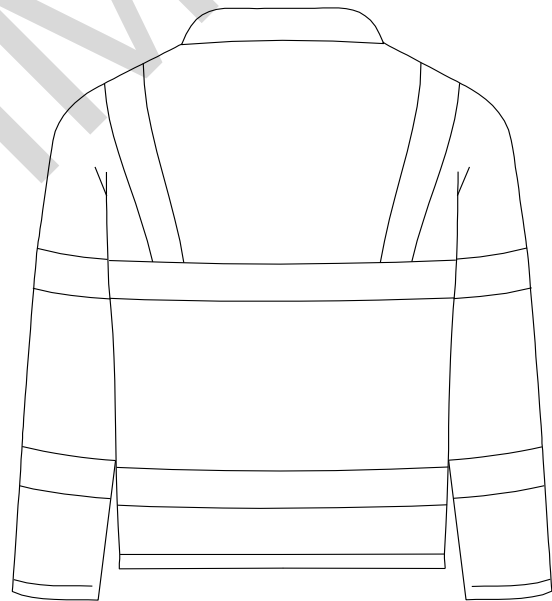

- The visibility strips are all 30mm wide.
- The high visibility jacket is to be made in standard unisex sizes as set out below.
- The final prototype should be made to a medium size.
- The waist and cuffs are to be elasticated.

	Small	Medium	Large	Extra Large
Neck size	410 mm	420 mm	430 mm	440 mm
Chest size	1000 mm	1060 mm	1120 mm	1180 mm
Cuff size	255 mm	255 mm	260 mm	260 mm
Sleeve length	850 mm	850 mm	860 mm	860 mm
Neck to hip	670mm	675 mm	685 mm	690 mm

Product 3 – Customer satisfaction panel (design engineering)

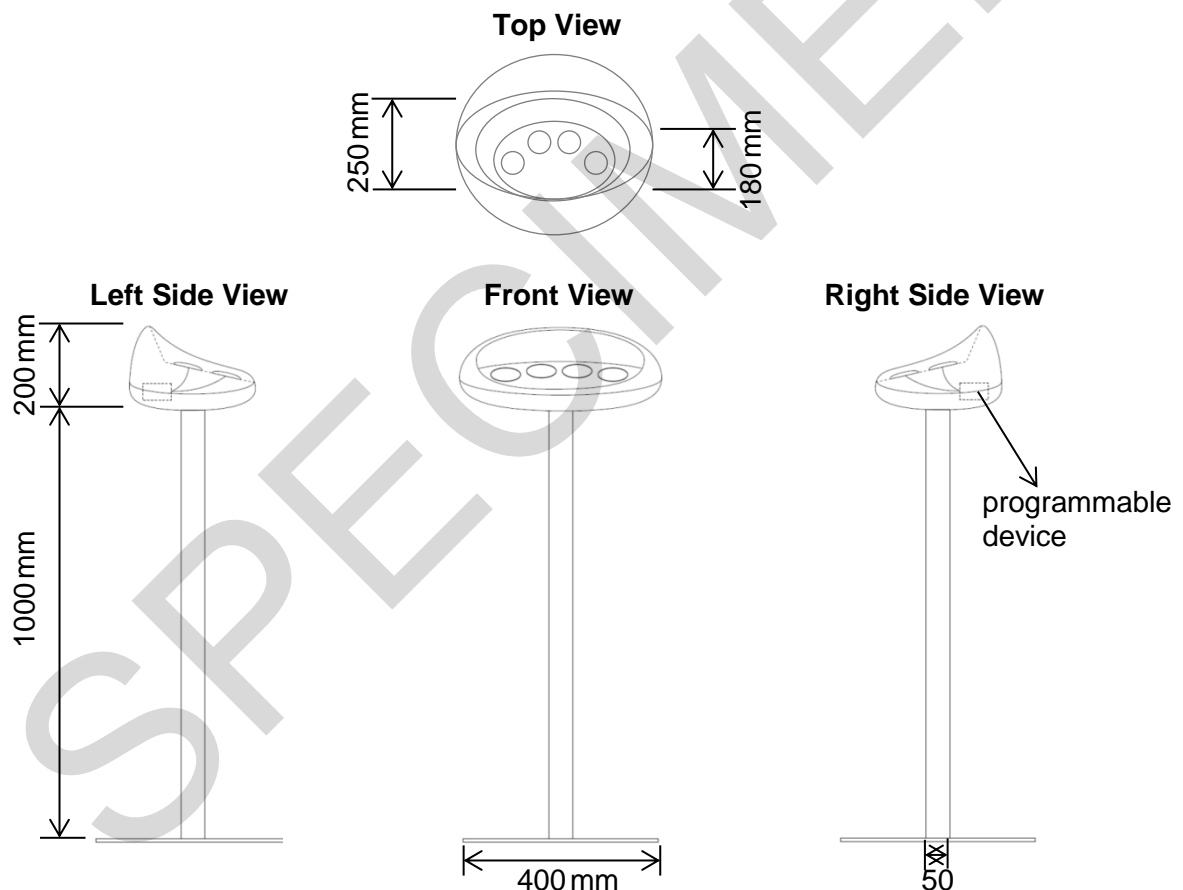
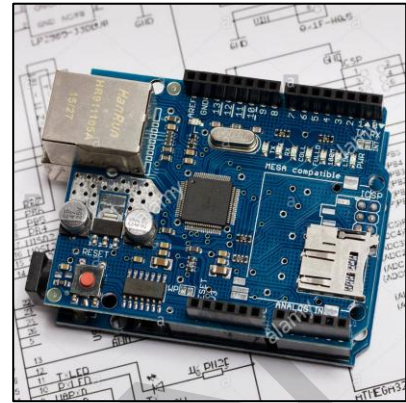

A customer satisfaction panel can be used to gain quick customer feedback by station users of the train station. When a voting button is pushed this selection is recorded through the use of a programmable device.

- The final prototype should demonstrate how the panel functions to a stakeholder. To do this you will have to use bought in electrical components, including the programmable device used to record the collection of data.
- The prototype should be made to a 1:1 scale to ensure the programmable device fits.

Product 4 - Retractable tape barrier (polymers)

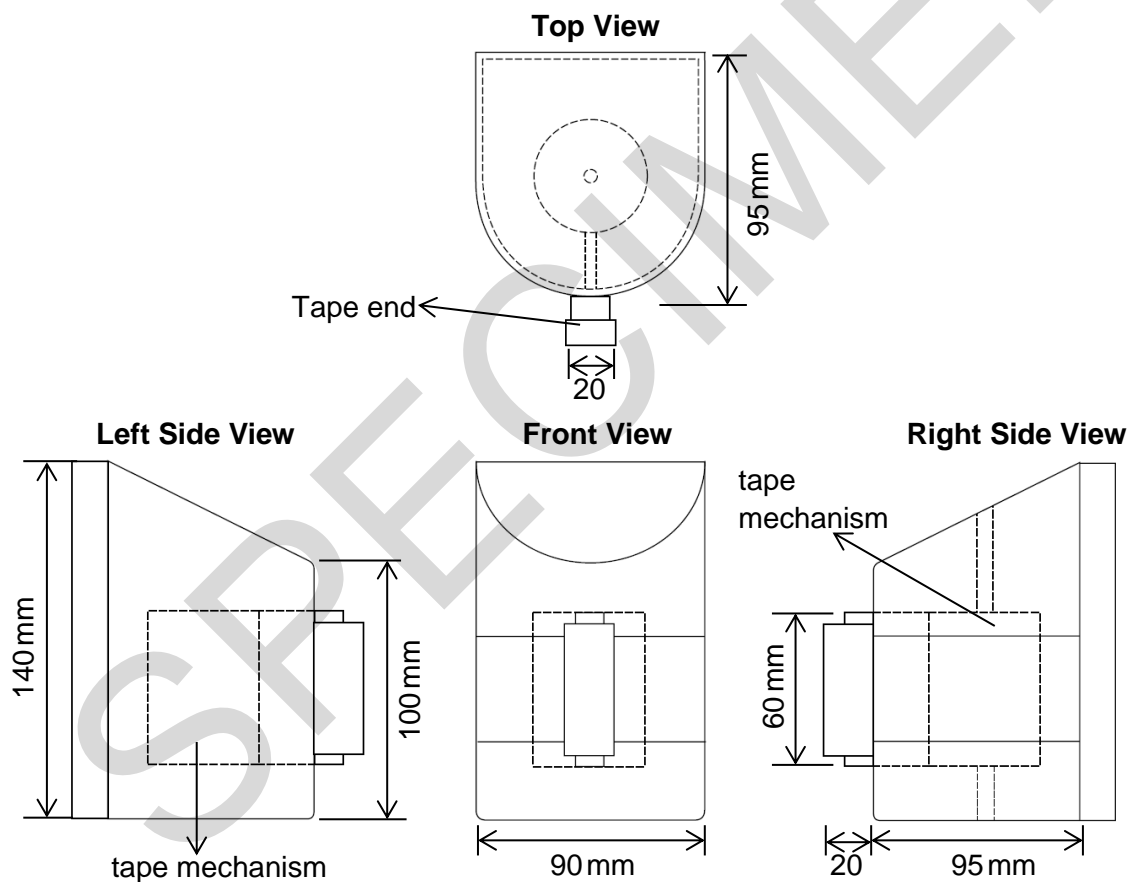

A retractable tape barrier is used to quickly close off stairways to control the flow of passengers in a train station.

- The retractable tape has a polymer end that can be attached to a fastening on the other side of a stairway. The tape mechanism used for the final prototype will be a standard bought in mechanism.
- The prototype should be made to a 1:1 scale to ensure the tape mechanism fits inside the prototype.

Product 5 – Toilet sign (metals)

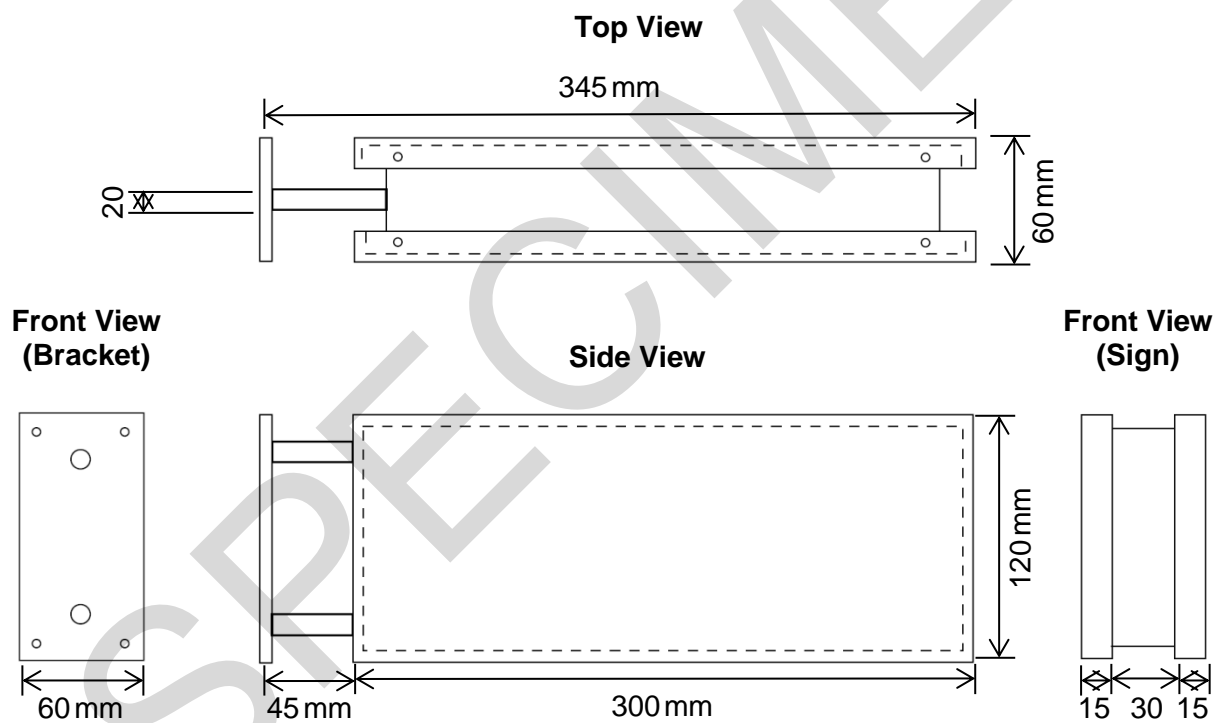

Each toilet sign is made in the same way, but the signage will vary dependent on what the sign is directing passengers to.

- The sign attaches to the wall using a bracket. The wall plate of the bracket section is made from 8mm thick material.
- The dotted lines on the plan represent the thinner white material that is fixed to the bracket section. The specific information for each sign is contained on the thinner material.

Product 6 – Flower planter (timbers)

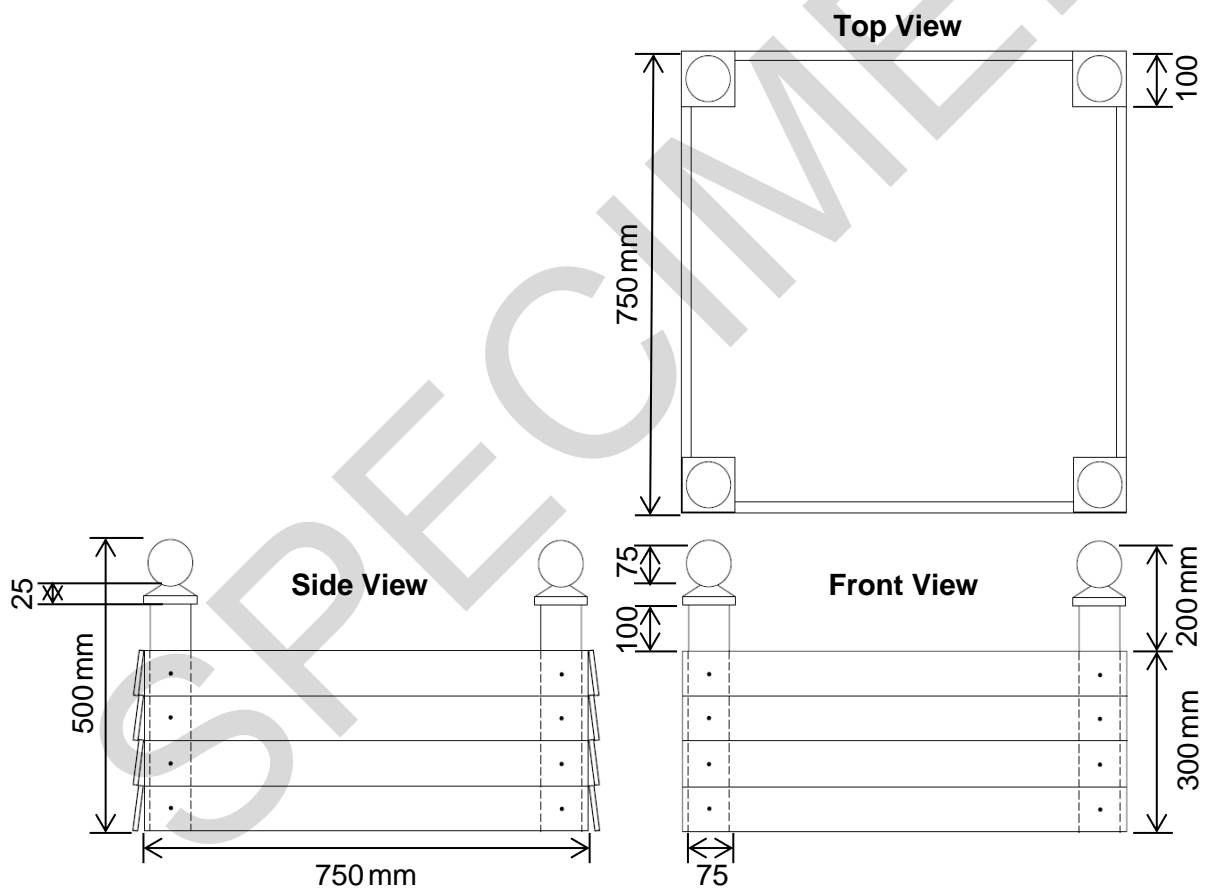

There are many flower planters of the same shape and size throughout the train station. The soil is contained within a thin polymer lining that sits tightly inside the planter.

- The planter is made using standard stock material that is cut and shaped.
- The posts are made from 75 mm square material.
- The ball ends are shaped from a cube of material that is 100 mm on all sides.

Information on this page is required to answer **Questions 4 and 5 (c)**.



Image A

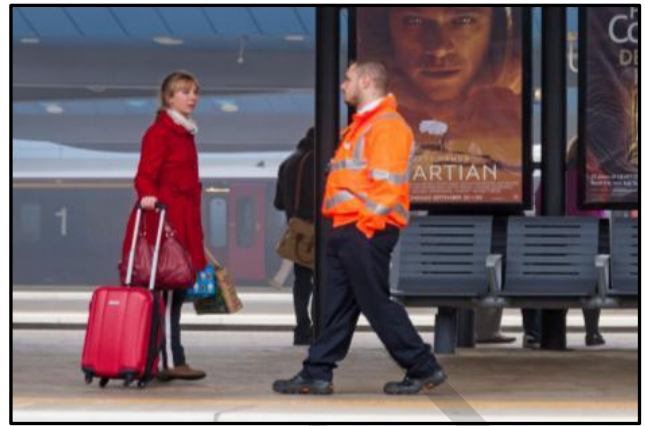

Image B



Image C



Image D

Copyright Information:

Image B: © www.almay.com (Ref: F7A78G)

OCR is committed to seeking permission to reproduce all third-party content that it uses in the assessment materials. OCR has attempted to identify and contact all copyright holders whose work is used in this paper. To avoid the issue of disclosure of answer-related information to candidates, all copyright acknowledgements are reproduced in the OCR Copyright Acknowledgements booklet. This is produced for each series of examinations and is freely available to download from our public website (www.ocr.org.uk) after the live examination series.

If OCR has unwittingly failed to correctly acknowledge or clear any third-party content in this assessment material, OCR will be happy to correct its mistake at the earliest possible opportunity.

For queries or further information please contact the Copyright Team, First Floor, 9 Hills Road, Cambridge CB2 1GE.

OCR is part of the Cambridge Assessment Group; Cambridge Assessment is the brand name of University of Cambridge Local Examinations Syndicate (UCLES), which is itself a department of the University of Cambridge.